

Real Time Implementation of Multimodel PI controller for Conical Tank

S.Kanagalaksmi ^{#1}, Dr.D.Manamalli ^{*2},

^{#1}Research scholar, ^{*2}Associate Professor,

Department of Instrumentation engineering, MIT Campus, Anna university, Chennai.

¹itkanaga@gmail.com, ²manamalli_m@yahoo.com

Abstract— The main aim of this study was to control the nonlinear process using multi-model PI controller. A multi model is developed for conical tank and it is validated against the real time setup conical tank process. A Multi model based PI controller is also developed, and implemented with real-time setup, and their performances are compared with that of the conventional controller of real time setup. The multimodal philosophy is based on the selection of a set of linear models, and the weighted sum of output from the multimodal N-PI has been used to control the nonlinear conical tank process.

Keyword- Multimodel, PI controller, conical Tank, Non-linear process, real time setup

I. INTRODUCTION

Conical tanks find wide applications in process industries, namely hydrometallurgical industries, food process industries, concrete mixing industries and wastewater treatment industries. Their shape contributes to better drainage of solid mixtures, slurries and viscous liquids. So control of conical tank resents a challenging problem due to its non-linearity and constantly changing cross section. It is considered to be a bench mark system which mimics the non-linearity and time varying nature in many industrial applications. Here conical tank process is taken up for study of multimodel and implementing the same concept in real-time setup. Linear control strategies provide powerful control design tools, but the main limitation is that, a single model developed around a particular operating condition may not be able to represent a plant in the full operating range when the plant dynamics exhibit nonlinearities. Classical control design tools may not be able to handle nonlinear processes effectively; they provide a number of methods for controller design, which incorporate robustness and performance requirements in a conventional way. Taking all these into account, the multi linear model approach is considered as a powerful design for developing a controller. The idea is to represent the nonlinear system as a combination of linear systems; to which conventional control design techniques can be applicable. The controller design based on multiple linear models requires either simultaneous stabilization of plants using a single controller, or an interpolation using membership functions. In this work, a real time validation study is conducted for 3 multi linear models on the developed model and validated with the real time conical tank variable area tank setup.

The organization of this paper is as follows. Section II and III the process and experimental hardware set-up are discussed. Section IV linear models are identified by conducting the open loop test of conical tank. Section V development of multimodel is discussed. Section VI Real-time implementation of Multimodel PI controller and without multimodel PI controller and results are discussed.

II. PROCESS DESCRIPTION

A. Mathematical Model of Conical Tank System

The Conical Tank system shown in figure 1 is a classical nonlinear bench mark problem. It consists of an inverted conical tank with an inlet flow (F_{in}) at top and an outlet flow (F_{out}) at the bottom, a pump that delivers the liquid flow and a control valve with coefficient (C_v) to manipulate F_{in} . This Conical Tank system is a single input single output (SISO) process in which the tank liquid level h is considered as the measured variable and the inlet flow F_{in} is considered as the manipulated variable. The mathematical model of the Conical Tank system is given by equation 1.

$$\left(\frac{dh}{dt}\right)^3 = \frac{Fin - CV\sqrt{2gh}}{\pi(R/H)^2} \quad (1)$$

Where,

- h – Level of liquid in the tank (m),
- F_{in} – Input flow to the tank (m^3/sec),
- C_v – Valve coefficient,
- g – Acceleration due to gravity (m/sec),
- R – Maximum radius of the tank (m),
- H – Maximum height of the tank (m).

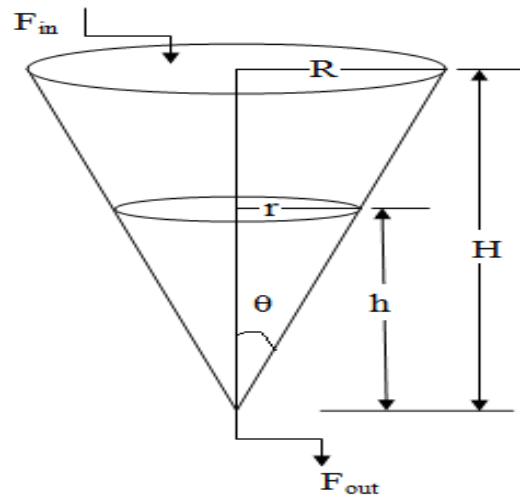

Fig.1. Schematic diagram of conical tank

The operating parameter of conical tank system is listed in Table 1.

TABLE 1: Operating Parameters Of Conical Tank System

Parameter	Description	Value
R	Top radius of conical tank	45cm
H	Maximum height of tank	60 cm
F_{in}	Maximum inlet flow to the tank	$2.7576 \times 10^{-4} \text{ m}^3/\text{sec}$

III.REAL TIME IMPLEMENTATION

The level of liquid in the tank is measured by EMERSON make (Model: 1151DP SMART) differential pressure transmitter whose output is in the form of 4-20 mA current signal. The control valve CV, is fitted with EMERSON make smart valve positioner which will take 3-15 psi as an input signal. Level transmitters and control valves are interfaced with PC with the help of USB 6008 DAQ device. There are two analog output channels (AO0, AO1) and eight analog input channels (AI0-AI7) in DAQ USB 6008. The current signal from transmitter is converted into voltage signal by a current to voltage (I-V) converter, so that it could directly be feed into the interfacing unit. Similarly the voltage signal from the interfacing unit is converted into current signal by a voltage to current (V-I) converter and then to pressure signal by a current to pressure (I-P) converter, so that it could be feed to the control valve to take corresponding control action.

The level transmitter is connected with the input channel AI-0 of the USB 6008 DAQ board through the I-V converter. The control signal in the form of 1-5 V voltage signal is generated from the output channel AO0 of USB DAQ board and connected to the control valve CV through the V-I converter and I-P converter. The real-time conical tank setup is shown in fig.2 (Available at Process control lab MIT Campus, Anna University, Chennai).



Fig. 2. Conical Tank Real time Setup

IV. REAL TIME MULTIMODEL IMPLEMENTATION

A. Real time Data Collection

The model identification of conical tank is carried out by conducting the open loop test in real time setup which is available in Department of Instrumentation Engineering, MIT Anna University, Chennai. The input F_{in} is varied in terms of voltage in lab view, by giving the step signal so as to capture the dynamics of the system. Inlet flow rate to the tank is taken as input, whereas the water level in the tank is taken as output. The input voltage is varied from 0 to 5 volt is generated from PC through DAQ USB6008. The AO is connected to V to I converter with a current signal in the range of 4- 20 mA and it is given to I to P converter. Output of level transmitter 4-20mA is converted into 0 to 5V voltage, and the acquired signal is fed to the DAQ through input channel AI. The steady state output (level) is obtained for the inlet flow 2V, 3V, and 4V. $F_{in}=2V$ corresponds to region 0 for the level ranging from 0 to 30cm. $F_{in}=3V$ corresponds to region 1 for the level ranging from 30 to 60cm. From the process reaction curve, the individual static gains K and τ for each operating region is calculated and obtained the FOPDT transfer function. The open loop response on conical tank i.e the inlet flow and tank level is shown in fig 3 and 4.

The transfer functions approximated are in the general form as given below in equation 2 and their respective values are tabulated, Table 2.

$$G = \frac{K_p}{\tau_p S + 1} \quad (2)$$

TABLE 2: Process Model at Different Operating Points

Region	Inlet Flow (voltage) F_{in}	Level(m)	Gain (K_p)	Time Constant (τ_p)
Region 0	3.5	20	0.5	1.566
Region 1	4	30	1.5	2.25
Region 2	4.5	40	1.2	2.8792

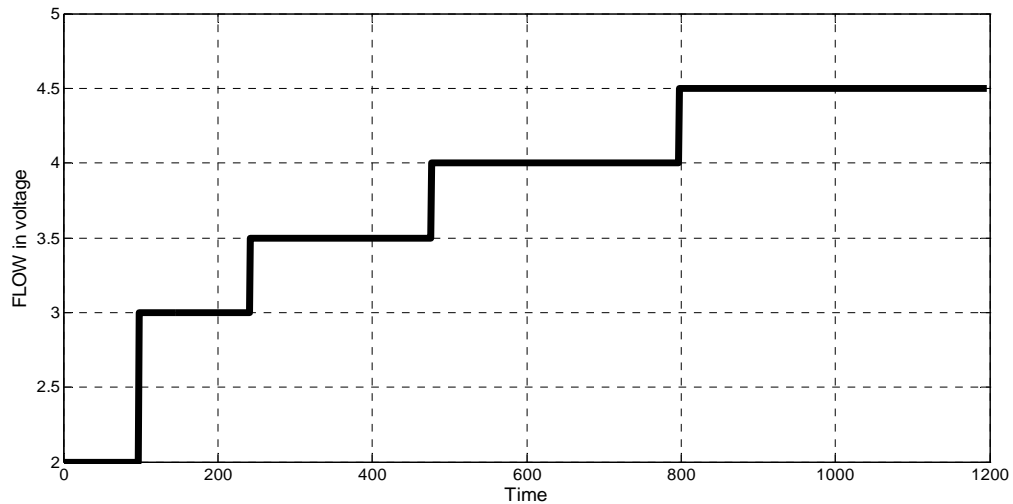

Fig. 3. Open loop step input of conical tank (matlab 2011)

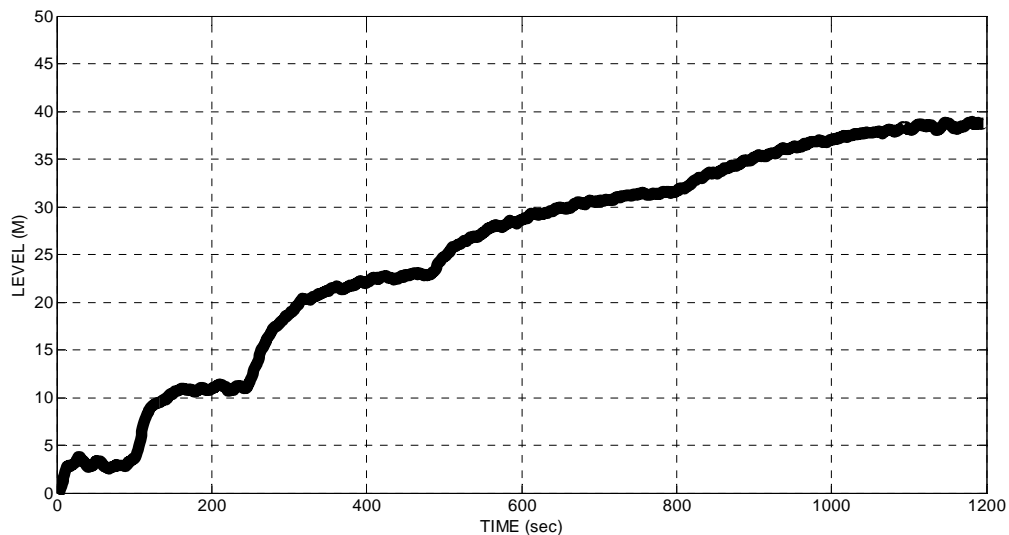

Fig. 4. Open loop Process response of Conical Tank

V. REAL TIME PI CONTROLLER IMPLEMENTATION

A. Multimodel PI controller

In the proposed work, a multimodel based control scheme has been developed. The multi model based control system consists of a family of controllers and a scheduler. At each sampling instant, the scheduler will assign weights to each controller and the weighted sum of the outputs will be applied as input to the plant. The scheduler will make its decision on the basis of a number of different variables such as manipulated inputs, measured disturbances etc.

To design the multiple model based controller, the nonlinear process has been linearized at “n” different operating points, and their corresponding transfer function models have been determined. The local PI controllers are designed for the developed multi model, and are used to control the non-linear process. The Level of the conical tank is assumed to have an operating range of 0cm to 60cm. In order to compensate for the non-linearity, the entire non-linear region is divided into the following three linear regions:

- Region 1 : 0 to 20cm
- Region 2 : 20 to 40 cm
- Region 3: 40 to 60 cm.

Individual multi models are developed for each of the above three regions. Accordingly, 3 individual PI controllers are designed one each for the three regions. If the level is in the range of 0 cm to 20 cm, the effect of the first controller alone will be felt. If the level is in the range of 20 to 40 cm, a combination of the effects of

the first and second controllers will be felt. If the level is in the region 40 to 60 cm, a combination of the second and third controller will act. The contribution of each controller will be decided by the weights that are generated, based on the current level measured value. The block diagram of multimodel PI controller is shown in figure 5. The weights are calculated according to the algorithms given below.

If $level \leq level1$, then

$$w_3 = 0; w_2 = 0; w_1 = 1$$

If $level1 \leq level \leq level2$, then

$$w_3 = 0; w_2 = (level - level1) / (level2 - level1); w_1 = 1 - w_2;$$

If $level2 \leq level \leq level3$, then

$$w_1 = 0; w_3 = (level - level2) / (level3 - level2); w_2 = 1 - w_3 ;$$

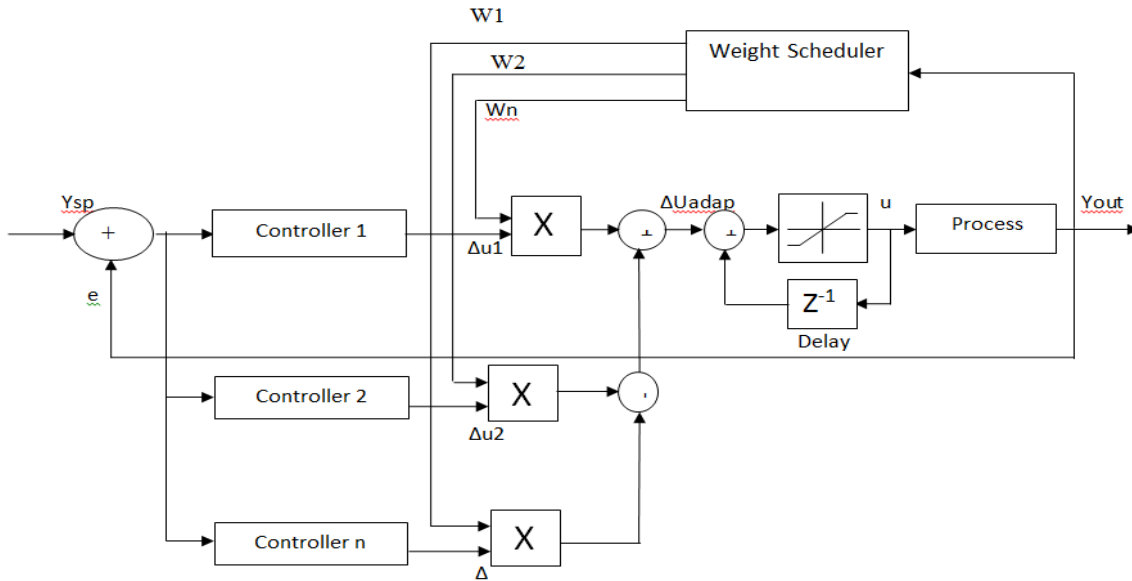

Fig.5. Block diagram of Multi model based PI controller.

The controller parameters are calculated using Direct Synthesis method. The formula for calculating the controller parameters are shown below in equation 3. The controller settings for Multimodel PI controller is listed in Table 3.

$$Kc = \frac{1}{Kp} ; \tau_i = \tau_p \text{ (sec)} \quad (3)$$

TABLE 3. PI controller settings of 3 regions

Region	P	I
Region 1 (0-20M)	1.695	0.378
Region 2 (20M -40M)	0.633	1.010
Region 3 (40M-60M)	0.390	1.166

VI. RESULTS AND DISCUSSION

A. PI Controllers for Conical Tank without Multimodel Approach-Real Time Implementation

The process is run with the conventional PI controller and results are presented for different set points. We have done the real time process in conical tank system available at Process control lab, Department of Instrumentation engineering, MIT, Anna University, Chennai. The closed loop responses of PI controller without multimodel approach is real time for the region 1, region 2 and region 3 are shown in figures 6, 7& 8. The performance criteria of the PI controller without Multi model in real time are given in Table 4.

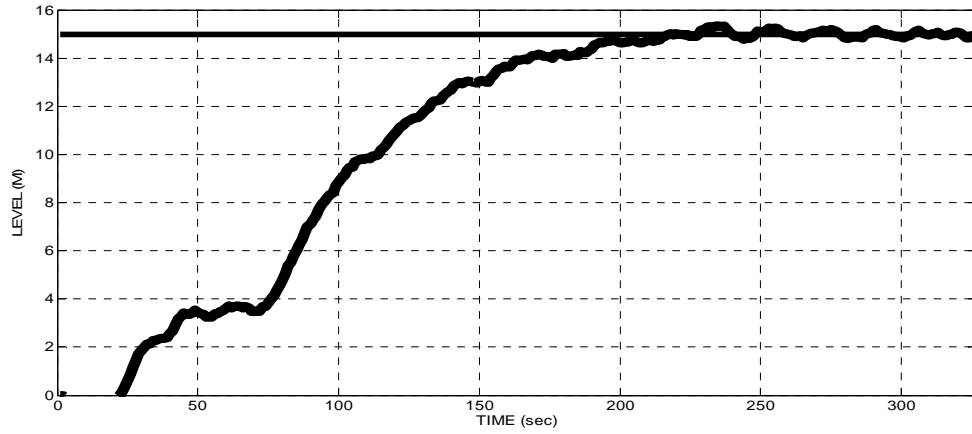

Fig. 6. Closed loop response for the set point of 15M without multimodel PI (Region 1)

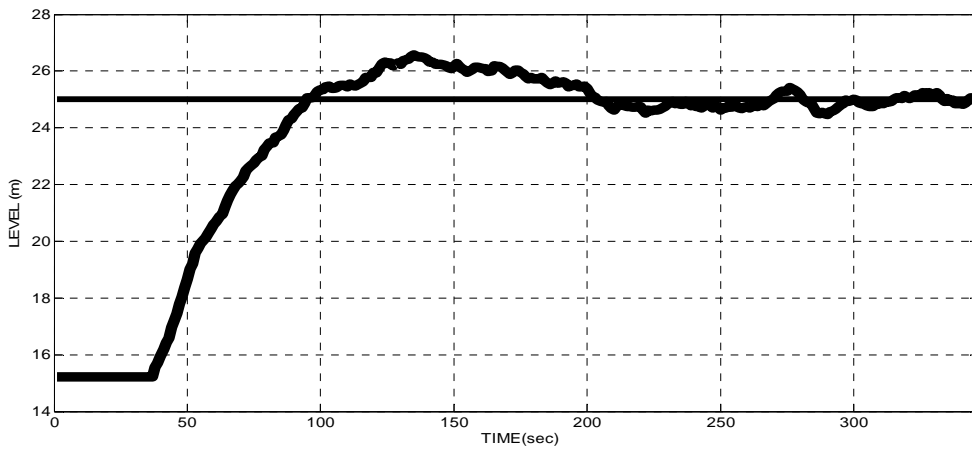

Fig. 7. Closed loop response for the set point of 25M without multimodel PI (Region 2)

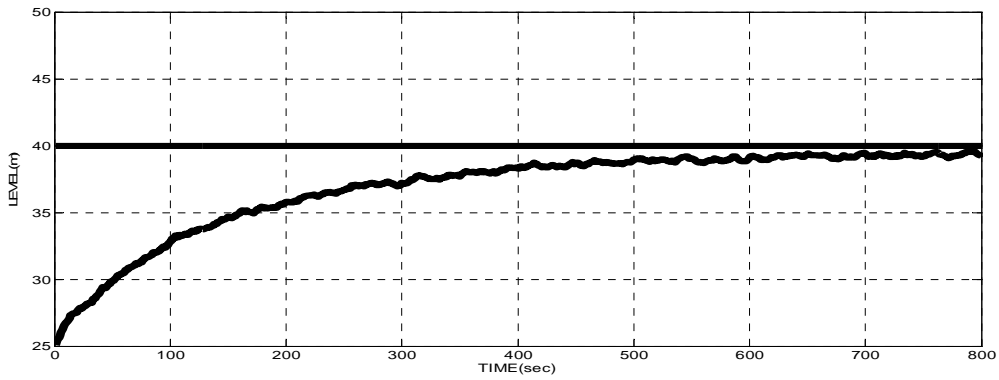

Fig. 8 .Closed loop response for the set point of 40M without multimodel PI (Region 3)

TABLE 4.Performance Criteria for PI controller without MM in Real time

REGION	IAE	ISE	SETTLING TIME (s)
Region 1 (0-20M)	$1.132 * 10^5$	8463	325
Region 2 (20M -40M)	$8.061 * 10^4$	$2.06 * 10^4$	345
Region 3 (40M-60M)	$5.202 * 10^4$	4302	862

B.PI Controllers for Conical Tank with Multimodel Approach-Real Time Implementation

The process is run with the Multi model based PI controller and the results are obtained. The Closed loop response of PI controller with multimodel approach in real time is shown in Figure 9 for different set points. The Controller output i.e the inlet flow of valve is shown in figure 10. The weight variation of controller is shown in figure 11.The performance criteria of the PI controller with Multi model in real time are given in Table 5.

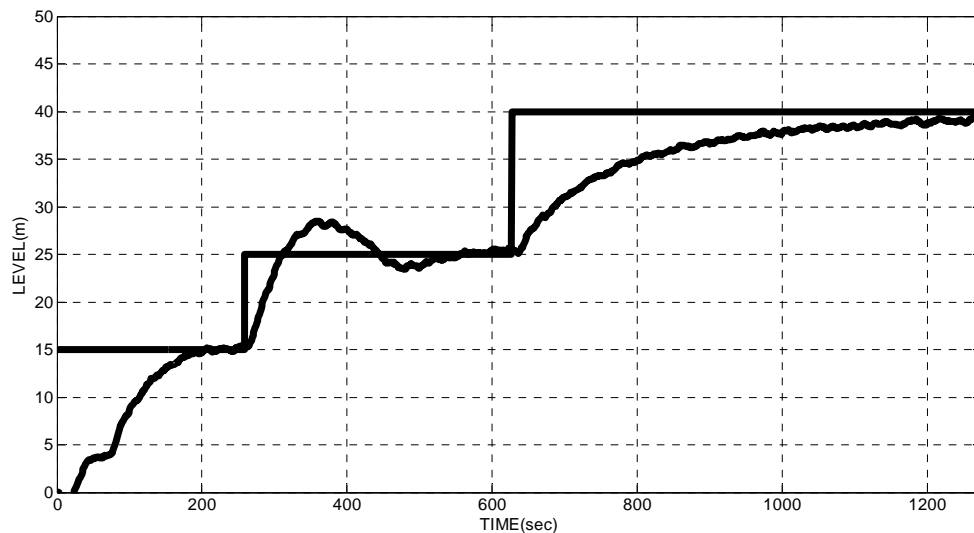

Fig. 9. Closed loop response for the 3 different set points of conical tank with multimodel PI

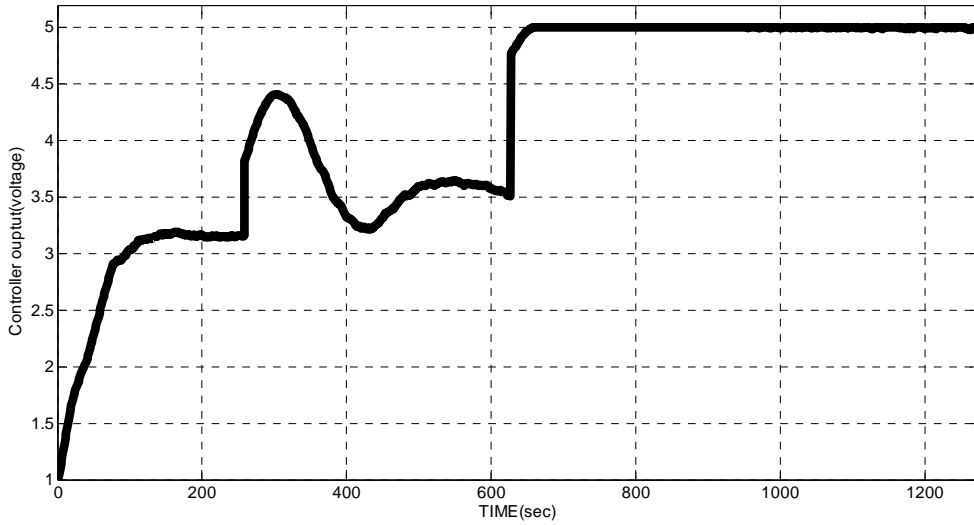

Fig.10. The MM PI controller output (inlet flow in voltage)

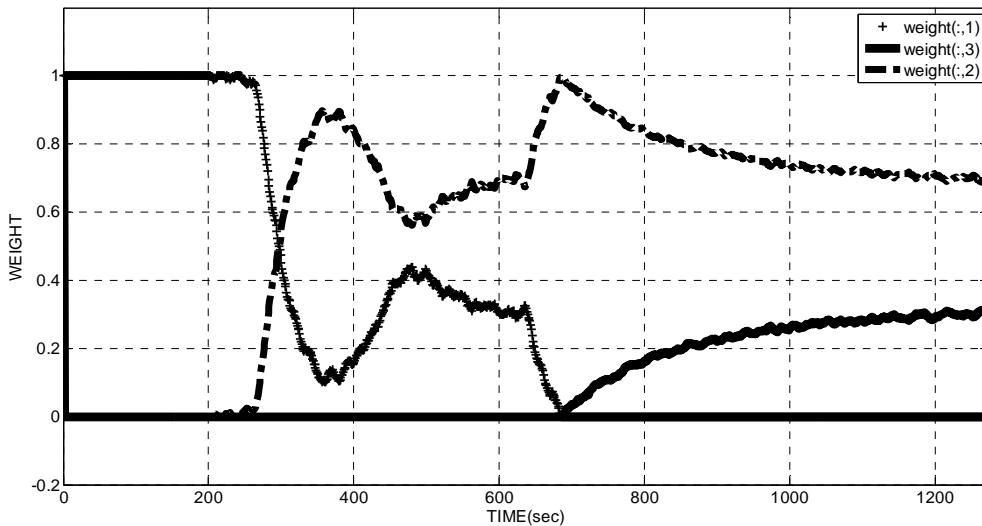

Fig.11.Weight Variation of Controller weights

In order to to access the tracking capability of designed controllers, set point variations have been given. From the response it can be inferred that, all the controllers designed for Conical tank system are able to maintain the desires level of the tank.

Table 5.Performance Criteria for PI controller with MM in Real time

Region	IAE	ISE	Settling Time (s)
Region 1 (0-20M)	1.61×10^6	3.13×10^4	257
Region 2 (20M -40M)	4.371×10^4	4975	298
Region 3 (40M-60M)	8.127×10^4	8284	642

VII. CONCLUSION

In this paper the real time results are obtained by collecting data from the conical tank set up available at Process control lab, MIT Campus, Anna University, Chennai. The conical tank system consists of three regions for which level control is required and the mathematical model for each region is different. Multimodel based PI control is used to achieve better performance. Three different controllers have been designed for control the level of the conical tank system. The conventional PI controller performance is analysed. The PI control with multi-model yields a better settling time, but it gives large IAE .The process was successfully controlled by PI controllers. However the IAE still remains large.

REFERENCES

- [1] B. Wayne Bequette, Process Control, Modeling, Design and Simulation, Prentice Hall, (2006).
- [2] N.S. Bhuvaneswari, G. Uma and T. R. Rangaswamy, "Neuro based Model Reference Adaptive control of a conical tank level process", Control and Intelligent Systems, vol. 36, No. 1, (2008), pp. 1-9.
- [3] R. Murray Smith and T. A. Johanson, Multiple model approaches to modeling and control, Taylor and Francis Ltd., (1997), chapter 11, pp. 269-291.
- [4] Omar Galan, Romagnoli , Ahmet Palazoglu, "Real time implementation of multi –linear model based control strategies-An application to a bench scale pH neutralization reactor",J. Process Control, 2004 , 14, 571-579.
- [5] Truong Nguyen Luan Vu and Moonyong Lee(2008), Multi-loop PI /PID controller Design nased on direct synthesis for multivariable systems. Processdings of the World Congress on engineering and Computer science.(WCECS-2008.)
- [6] R. Vinodha, M. Natarajan and J. Parkash, "Simple Adaptive control schemes for a spherical tank process", Journal of system science and Engineering, A Publication of Systems Society of India, vol. 17, No. 2, (2008), pp. 55-60.
- [7] J. Prakash and K. Srinivasan, "Design of nonlinear PID controller and nonlinear model predictive controller for a continuous stirred tank reactor", ISA Transactions, vol. 48, No. 3, (2009), pp. 273-282.
- [8] Anna Joseph and Samson Isaac, "Real time Implementation of Model Reference Adaptive controller for a Conical Tank Process", International Journal on Theoretical and Applied Research in Mechanical Engineering,(2013), vol.2, No. 1, pp.57-62.